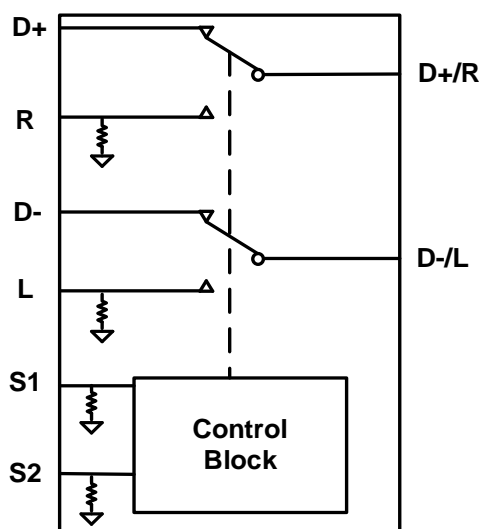

## GT4321

### USB2.0 High-Speed and Audio Switches with negative Signal Capability

1 Features	2 Application
<ul style="list-style-type: none"> <li>- Supply Range: 2.7V to 5.0V</li> <li>- -3 dB Bandwidth: 800MHz (USB Mode)</li> <li>- Off Isolation: -69dB at 1MHz</li> <li>- Crosstalk Rejection: -87dB at 1MHz</li> <li>- Low On Resistance: 2.5-ohm at Vcc=3.6V (Audio Mode) 8.5-ohm at Vcc=3.6V (USB Mode)</li> <li>- Analog Signal Range: Vcc-6.5V to Vcc-2V (Audio Mode) 0V to Vcc (USB Mode)</li> <li>- Audio Channel Shunt Resistors for Pop &amp; Click Noise Reduction</li> <li>- Power-off Protection on Common D+/R, D-/L Ports</li> </ul>	<ul style="list-style-type: none"> <li>- Cell Phones</li> <li>- Hi-Fi Audio Switching</li> <li>- Portable Instrumentation</li> <li>- USB 2.0 High Speed Data Switching</li> <li>- USB 3.x Type C Switching</li> </ul>

3 Description	Circuit Diagram
<p>The GT4321 is a double-pole double-throw(DPDT) analog switch with multiplexes USB2.0 and negative signal audio analog signals. One Channel has wide bandwidth and low bit-to-bit skew allow it to pass high-speed differential signals with good signal integrity. Another channel has ultra-Low on resistance (2.5Ω). Each switch is bidirectional and offers little or no attenuation of the signals at the outputs. Industry-leading advantages include a propagation delay of less than 250ps, resulting from its low channel resistance and low I/O capacitance. Their high channel-to-channel crosstalk rejection results in minimal noise interference.</p> <p>The GT4321 is available in Green QFN1.4*1.8-10 packages. It operates over an ambient temperature range of -40°C to +125°C.</p>	 <p>The circuit diagram illustrates the internal structure of the GT4321 as a double-pole double-throw (DPDT) switch. On the left side, there are six input terminals: D+, R, D-, L, S1, and S2. On the right side, there are two output terminals: D+/R and D-/L. A vertical dashed line represents the switch mechanism. The D+ and D- inputs are connected to the top and bottom poles of the switch, respectively. The R and L inputs are connected to the common terminals of the switch. The S1 and S2 inputs are connected to a 'Control Block' which provides the switching signal. The output terminals D+/R and D-/L are connected to the switch outputs. The diagram also shows resistors connected to the R and L inputs, and the S1 and S2 inputs.</p>

## 4 Revision History

Revision	Date	Note
Rev. A0. 1	2024. 11. 05	Original Version

The latest datasheet version should be checked on the GTIC official website, as the company does not actively inform customers about updates to the datasheet.

## 5 Device Summary, Pin and Packages

**Table 5-1. Device Summary<sup>(1)</sup>**

Serial Name	Part Name	Package	Body Size (Nom)	Marking <sup>(2)</sup>	MSL <sup>(3)</sup>	Package Qty
GT4321	GT4321QA	QFN1.4*1.8-10L	1.40mm*1.80mm*0.55mm	4321 XXXX	3	Tape and Reel,3000

(1) For all available packages, please contact product sales.

(2) There may be additional marking, which relates to the lot trace code information (data code and vendor code), the logo or the environmental category on the device.

(3) MSL, The Moisture Sensitivity Level rating according to the JEDEC industry standard classifications.

(4) "XXXXX" in Marking will be appeared as the batch code.

5 Device Summary, Pin and Packages(Continued)

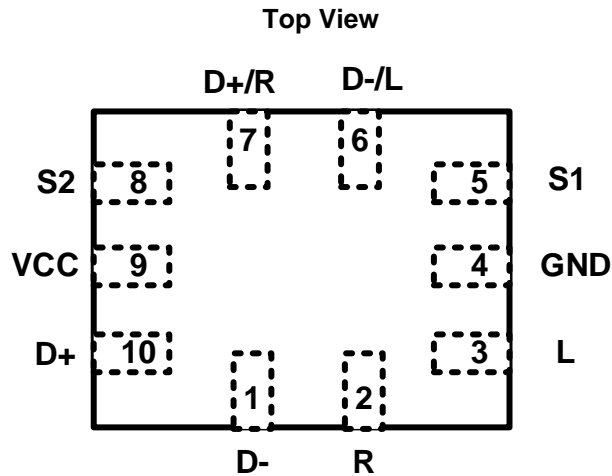

Fig.5-1.GT4321: QA (QFN1.4\*1.8-10L) Package

Table 5-2 Pin Description

Name	Pin Number	Description
D-	1	USB data bus DATA
R	2	Audio right
L	3	Audio left
GND	4	Power Ground
S1	5	Logic Control Input 1
D-/L	6	USB and audio common connector ports
D+/R	7	USB and audio common connector ports
S2	8	Logic Control Input 2
Vcc	9	Power Supply
D+	10	USB data bus DATA+

Table 5-3 Logic Function Table

S1	S2	Audio Mode	USB Mode	Remarks
0	0	ON	OFF	Audio On
0	1	OFF	ON	USB Communication
1	0	OFF	OFF	Low Power Mode
1	1	ON	OFF	Audio On

## 6 Voltage, Temperature, ESD and Thermal Ratings

### 6.1 Absolute Maximum Ratings

Parameters	Min.	Max.	Unit
Vcc, S1, S2, D+, D- to GND	-0.65	5.25	V
All Other Pins to GND	Vcc-6.5	(Vcc)+0.3	V
Continuous Current (D+/D-,R/L, D+/R,D-/L)	-150	+150	mA
Peak Current (D+/D-,R/L, D+/R,D-/L)(pulsed at 1ms, 10% duty cycle)	-250	+250	mA
Junction Temperature		150	°C
Storage Temperature	-65	150	°C

(1) Stresses beyond those listed under "Absolute Maximum Ratings" may cause permanent damage to the device. These are stress ratings only, and functional operation of the device at these or any other conditions beyond those indicated under "Recommended Operating Conditions" is not implied. Exposure to absolute-maximum-rated conditions for extended periods may affect device reliability.

(2) The input and output negative-voltage ratings may be exceeded if the input and output current ratings are observed.

### 6.2 ESD Ratings

ESD		Value	Unit	
V(ESD)	Electrostatic Discharge	Human-Body Model (HBM)	5.5K	V
		Charged-Device Model (CDM)	2K	V

(1) JEDEC document JEP155 states that 500-V HBM allows safe manufacturing with a standard ESD control process.

(2) JEDEC document JEP157 states that 250-V CDM allows safe manufacturing with a standard ESD control process.

### 6.3 Recommended Operating Conditions

Over operating free-air temperature range (unless otherwise noted)

Symbol	Parameter	Min	Max	Unit
Vcc	Supply Voltage	2.7	5.0	V
T <sub>A</sub>	Operating Temperature	-40	125	°C

(1) All unused digital inputs of the device must be held at Vcc or GND to ensure proper device operation.

### 6.4 Thermal Information

Package Type	$\theta_{JA}$	$\theta_{JC}$	Unit
QFN1.4*1.8-10L	120	46	°C/W

## 7 Electrical Specifications

V<sub>CC</sub>=2.7V to 5V, GND=0V, FULL=-40°C to +125°C. Typical values are at V<sub>CC</sub>=3.6V, T<sub>A</sub>=+25°C. (unless otherwise noted)

Parameter	Symbol	Conditions	Temp	Min	Typ	Max	Units
<b>Power Supply</b>							
Supply Voltage Range	V <sub>CC</sub>		FULL	2.7		5	V
Supply Current	I <sub>CC</sub>	V <sub>CC</sub> =3.6V, S1,S2=0 or V <sub>CC</sub> , D+/-,R/L,D-/L,D+/R=floating	FULL		0.01	1	μA
<b>USB Switch</b>							
Analog Signal Range		USB mode, D+, D-, D+/R,D-/L	Full	0		V <sub>CC</sub>	V
On-Resistance	R <sub>ON</sub>	I <sub>SW</sub> =8mA, V <sub>D+</sub> , V <sub>D-</sub> =0 to V <sub>CC</sub>	+25°C		8.5		Ω
On-Resistance Match	ΔR <sub>ON</sub>	I <sub>SW</sub> =8mA, V <sub>D+</sub> , V <sub>D-</sub> =0 to V <sub>CC</sub>	+25°C		0.5		Ω
On-Resistance Flatness	R <sub>FLAT</sub>	I <sub>SW</sub> =8mA, V <sub>D+</sub> , V <sub>D-</sub> =0 to V <sub>CC</sub>	+25°C		2.5		Ω
D+,D- Off-Leakage Current	I <sub>OFF</sub>	Audio mode, V <sub>D+/R</sub> , V <sub>D-/L</sub> =floating	Full			100	nA
D+,D-, On-Leakage Current	I <sub>ON</sub>	USB mode, V <sub>D+/R</sub> , V <sub>D-/L</sub> =floating	Full			100	nA
<b>Audio Switch</b>							
Analog Signal Range		Audio mode ,R, L, D+/R, D-/L	Full	V <sub>CC</sub> -6.5		V <sub>CC</sub> -2	V
On-Resistance	R <sub>ON</sub>	I <sub>SW</sub> =60mA, V <sub>R</sub> , V <sub>L</sub> =-1V to 1V	+25°C		2.5		Ω
On-Resistance Match	ΔR <sub>ON</sub>	I <sub>SW</sub> =60mA, V <sub>R</sub> , V <sub>L</sub> =-1V to 1V	+25°C		0.2		Ω
On-Resistance Flatness	R <sub>FLAT</sub>	I <sub>SW</sub> =60mA, V <sub>R</sub> , V <sub>L</sub> =-1V to 1V	+25°C		0.4		Ω
Shunt Resistance	R <sub>SH</sub>	USB mode, I <sub>L</sub> , I <sub>R</sub> =5mA	+25°C		4		kΩ
<b>Digital Inputs</b>							
Input-Logic High	V <sub>IH</sub>	V <sub>CC</sub> =2.7V	Full	1.7			V
		V <sub>CC</sub> =5V	Full	2.7			
Input-Logic Low	V <sub>IL</sub>	V <sub>CC</sub> =2.7V	Full			0.5	V
		V <sub>CC</sub> =5V	Full			1	
Input Leakage Current High	I <sub>IH</sub>	V <sub>CC</sub> =V <sub>IN</sub> =3.6V	Full		2	10	μA
Input Leakage Current Low	I <sub>IL</sub>	V <sub>CC</sub> =3.6V, V <sub>IN</sub> =0V	Full	-1		1	μA

## 7 Electrical Specifications(Continued)

V<sub>CC</sub>=2.7V to 5V, GND=0V, FULL=-40°C to +125°C. Typical values are at V<sub>CC</sub>=3.6V, T<sub>A</sub>=+25°C. (unless otherwise noted)

Parameter	Symbol	Conditions	Temp	Min	Typ	Max	Units
Turn-On Time	t <sub>ON</sub>	V <sub>R</sub> or V <sub>L</sub> or V <sub>D+</sub> or V <sub>D-</sub> =1.5V, R <sub>L</sub> =50 Ω, C <sub>L</sub> = 35pF	+25°C		16		ns
Turn-Off Time	t <sub>OFF</sub>	V <sub>R</sub> or V <sub>L</sub> or V <sub>D+</sub> or V <sub>D-</sub> =1.5V, R <sub>L</sub> =50 Ω, C <sub>L</sub> = 35pF	+25°C		8		ns
Break-Before-Make Delay	t <sub>BBM</sub>	V <sub>R</sub> or V <sub>L</sub> or V <sub>D+</sub> or V <sub>D-</sub> =1.5V, R <sub>L</sub> =50 Ω, C <sub>L</sub> =35pF	+25°C		7		ns
-3 dB Bandwidth	BW	USB mode, R <sub>L</sub> =50 Ω	+25°C		800		MHz
Off-Isolation	OIRR	D+/R, D-/L=0.5 V <sub>PP</sub> , R <sub>L</sub> =50 Ω, f=1MHz, C <sub>L</sub> =5pF	+25°C		-69		dB
Crosstalk	XTALK	D+/R, D-/L=0.5 V <sub>PP</sub> , R <sub>L</sub> =50 Ω, f=1MHz, C <sub>L</sub> =5pF	+25°C		-87		dB
Total Harmonic Distortion Plus Noise	THD+N	Audio mode, f=20Hz to 20kHz; V <sub>R</sub> or V <sub>L</sub> =0.5V <sub>PP</sub> , R <sub>L</sub> =32 Ω	+25°C		0.002		%
D+,D- Off-Capacitance	C <sub>OFF</sub>	Audio mode, f=1MHz	+25°C		3		pF
D+,D- On-Capacitance	C <sub>ON</sub>	USB mode, f=1MHz, V <sub>D+/R</sub> or V <sub>D-/L</sub> =floating	+25°C		8		pF

### 8 Measurement Information

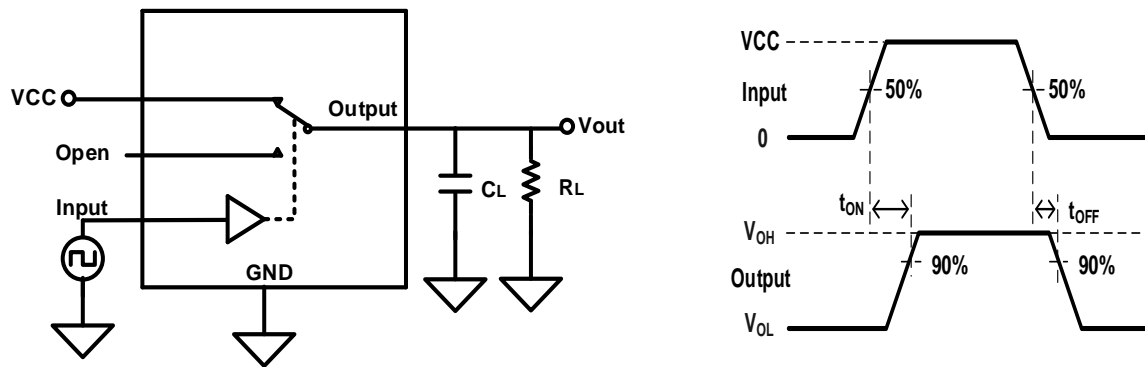

Fig.8-1. Turn-On ( $t_{ON}$ ) and Turn-Off Time ( $t_{OFF}$ )

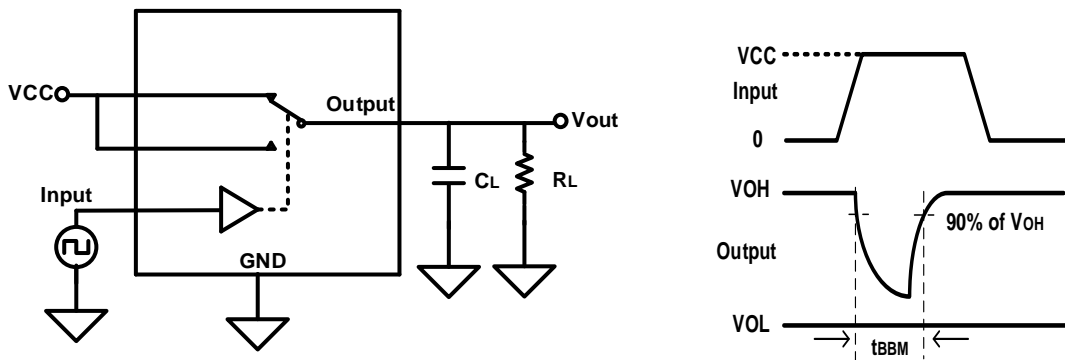

Fig.8-2. Break-Before-Make Time Delay ( $t_{BBM}$ )

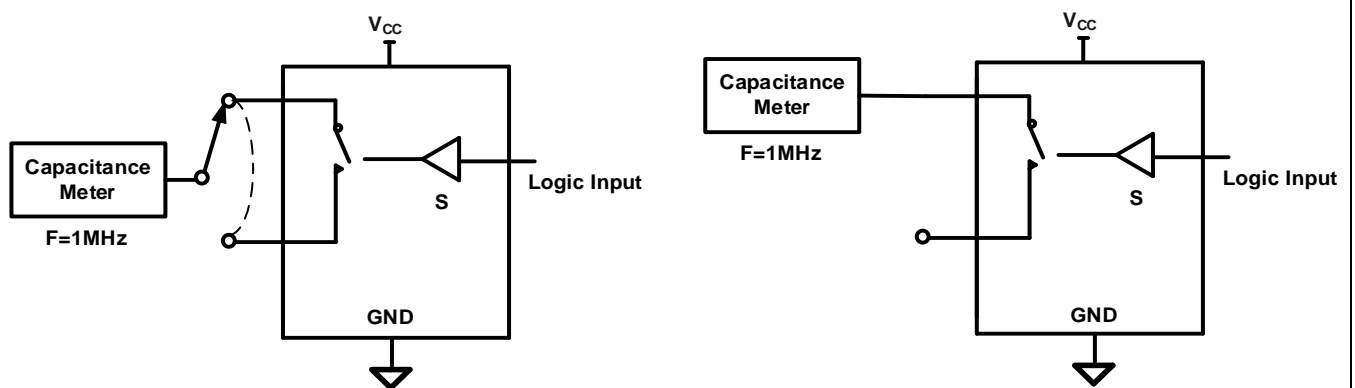

Fig.8-3. Channel ON/OFF Capacitance



8 Measurement Information(Continued)

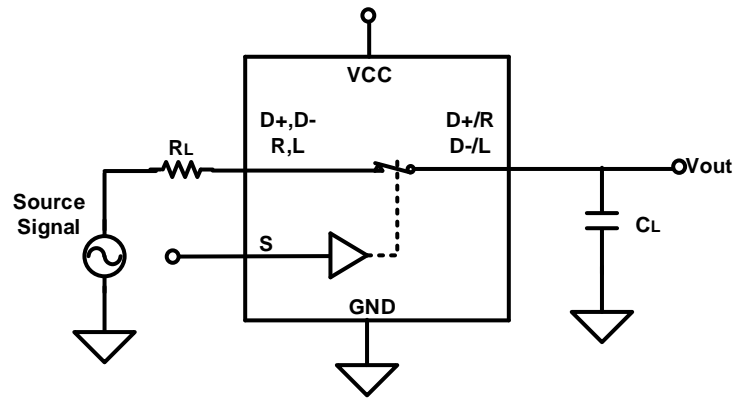
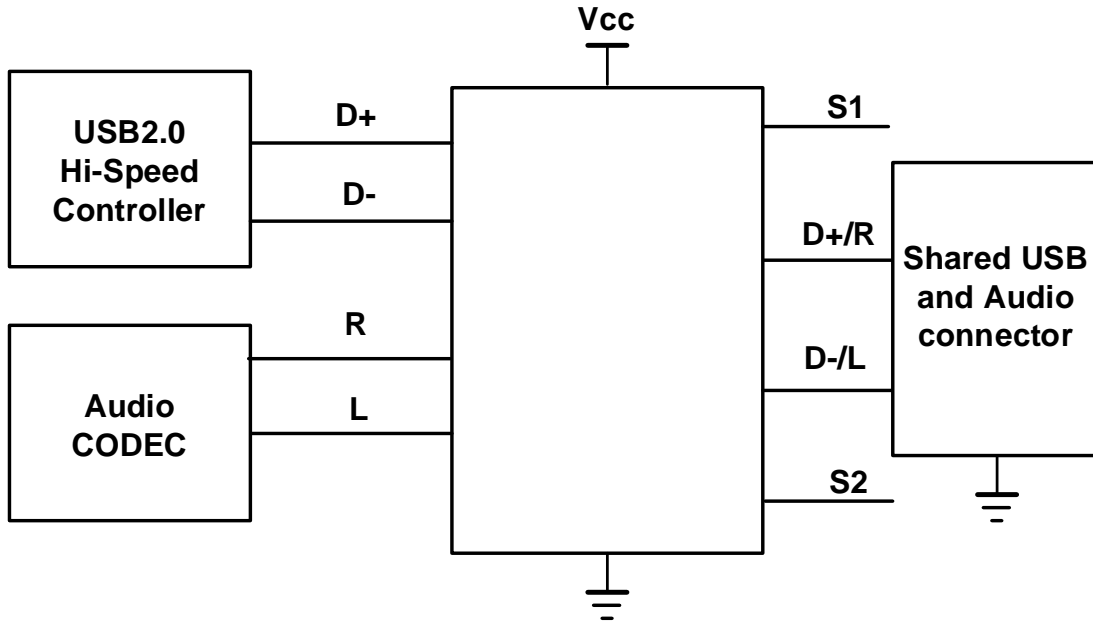

Fig.8-4. -3dB Bandwidth

**9 Applications Note**



**Fig.9-1. Typical Application Circuit**

# 10 Package Outline Dimension

QFN1.4\*1.8-10L

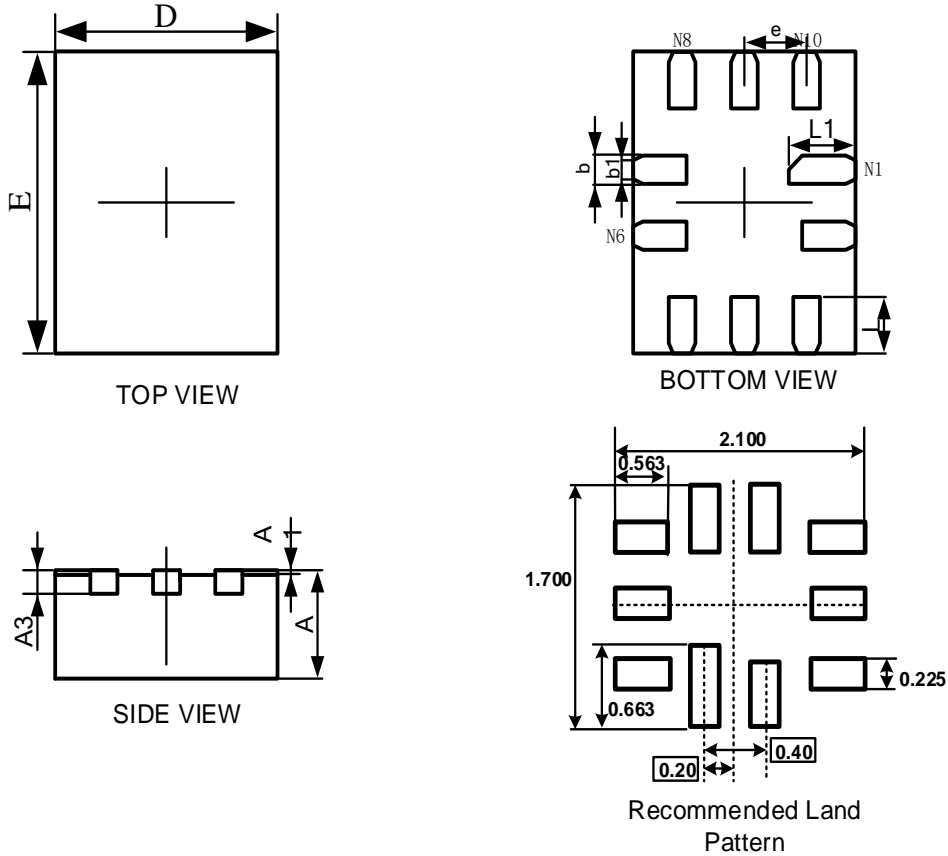

Symbol	Dimensions in Millimeters		Dimensions in Inches	
	Min	Max	Min	Max
A	0.500	0.600	0.020	0.024
A1	0.000	0.050	0.000	0.002
A3	0.152REF		0.006REF	
D	1.350	1.450	0.053	0.057
E	1.750	1.850	0.069	0.073
D1	—	—	—	—
E1	—	—	—	—
k	—		—	
b	0.150	0.250	0.006	0.010
b1	0.100	0.200	0.004	0.008
e	0.400TYP		0.016TYP	
L	0.350	0.450	0.014	0.018
L1	0.450	0.550	0.018	0.022

## 11 Tape and Reel Information

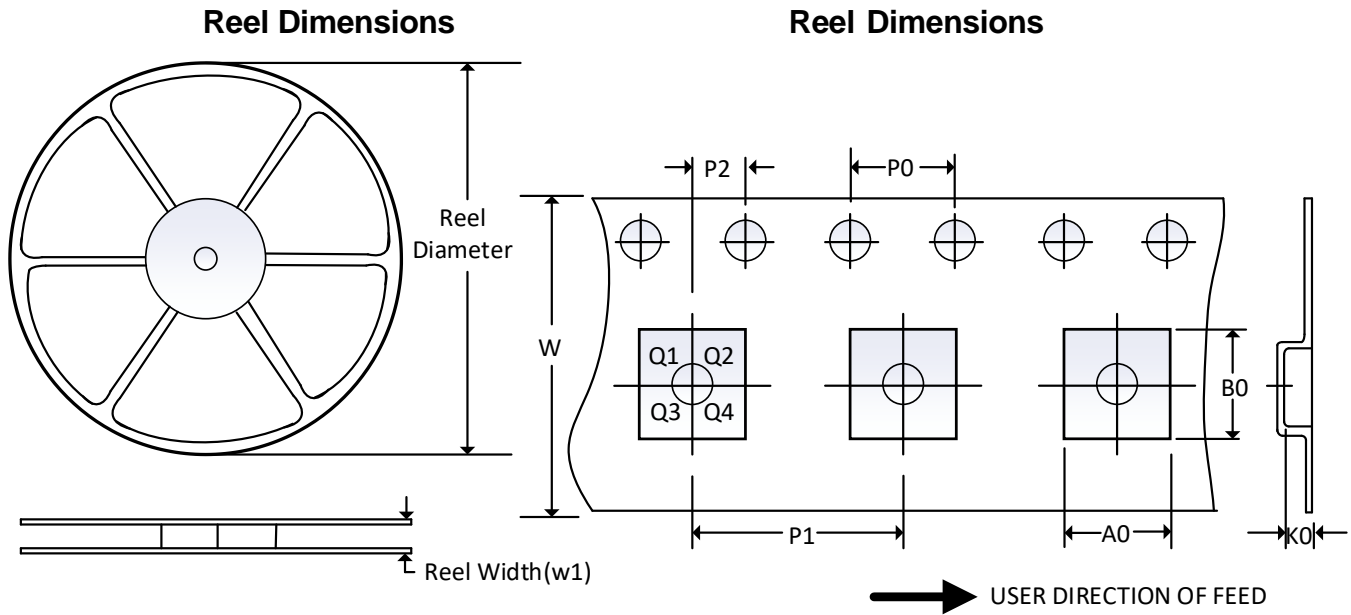

NOTE: The picture is only for reference. Please make the object as the standard.

### Key Parameter List of Tape and Reel

Package Type	Reel Diameter	Reel Width (mm)	A0 (mm)	B0 (mm)	K0 (mm)	P0 (mm)	P1 (mm)	P2 (mm)	W (mm)	Pin1 Quadrant
QFN1.4*1.8-10L	7"	9	1.6	2	0.85	4.0	4.0	2.0	8.0	Q1

NOTE:

1. All dimensions are nominal.
2. Plastic or metal protrusions of 0.15mm maximum per side are not included.