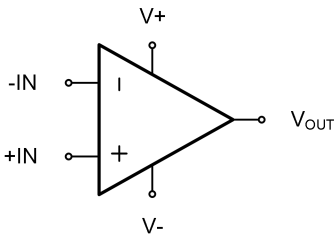

## GT321 GT358 GT324 High Voltage General Purpose Operational Amplifier

1 Features	2 Application
<ul style="list-style-type: none"> <li>- Ultra-low input offset voltage: <math>\pm 3\text{mV}</math></li> <li>- Power supply voltage: <math>+3\text{V}</math> to <math>+36\text{V}</math></li> <li>- Support single and dual power supply</li> <li>- Low quiescent current: <math>100\mu\text{A}/\text{channel}</math></li> <li>- Low wideband noise: <math>35\text{nV}/\sqrt{\text{Hz}}</math></li> <li>- Rail to Rail output</li> <li>- Unity-bandwidth gain: <math>1.5\text{ MHz}</math></li> <li>- Operating temperature range: <math>-40^\circ\text{C}</math> to <math>+125^\circ\text{C}</math></li> </ul>	<ul style="list-style-type: none"> <li>- Motordriver</li> <li>- Sensor module</li> <li>- Household appliances</li> <li>- Power supply module</li> <li>- Inverter</li> <li>- UPS</li> <li>- Air conditioning inside and outside</li> <li>- Automotive electronics</li> </ul>

3 Description	Circuit Diagram
<p>GT321,GT358,GT324 high-voltage general purpose operational amplifiers from GTIC is manufactured using advanced processes with full process standardization and control. The series includes single op-amp(GT321), dual op-amp(GT358), and quad op-amp(GT324), which feature unique circuit design techniques and classic rail-to-rail input/output swing. They exhibit high consistency and symmetry within the entire working voltage and temperature range, making them particularly suitable for applications that have high cost requirements and limited space, where the amplifiers can be well-coordinated and balanced with the overall circuit design.</p> <p>GT321,GT358,GT324 chips includes builtin over load protection circuits that allow the amplifier store cover from overloads and resume operation in a short amount of time, greatly enhancing the circuit's reliability.</p>	

## 4 Device Summary, Pin and Packages

Table 4-1. Device Summary<sup>(1)</sup>

Serial Name	Part Name	Package	Body Size (Nom)	Marking <sup>(2)</sup>	MSL <sup>(3)</sup>	Package Qty
GT321	GT321S5	SOT23-5	2.90mm×1.60mm×1.10mm	GT321 XXXXXX	3	Tape and Reel,3000
	GT321BS5	SOT23-5	2.90mm×1.60mm×1.10mm	GT321B XXXXXX	3	Tape and Reel,3000
GT358	GT358F8	DFN2*2-8L	2.00mm×2.00mm×1.10mm	358 XXXX	3	Tape and Reel,3000
	GT358P8	SOP8	4.90mm×3.90mm×1.75mm	GT358 XXXXXXXX	3	Tape and Reel,4000
	GT358T8	TSSOP8	3.00mm×4.40mm×1.10mm	GT358 XXXXXXXX	3	Tape and Reel,4000
	GT358M8	MSOP8	3.00mm×3.00mm×1.10mm	GT358 XXXXXXXX	3	Tape and Reel,4000
GT324	GT324PD	SOP14	8.65mm×3.90mm×1.75mm	GT324 XXXXXXXX	3	Tape and Reel,4000
	GT324TD	TSSOP14	5.00mm×4.40mm×1.20mm	GT324 XXXXXXXX	3	Tape and Reel,4000

(1) For all available packages, please contact product sales.

(2) There may be additional marking, which relates to the lot trace code information (data code and vendor code), the logo or the environmental category on the device.

(3) MSL, The Moisture Sensitivity Level rating according to the JEDEC industry standard classifications.

(4) "XXXXXX" in Marking will be appeared as the batch code.

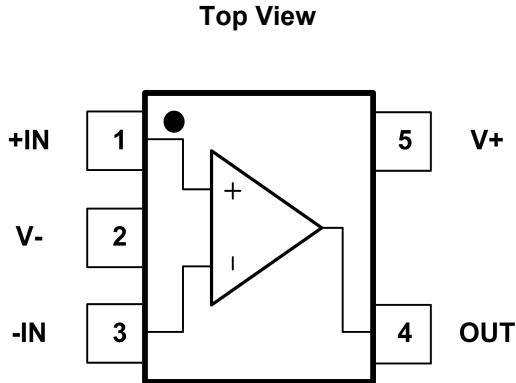
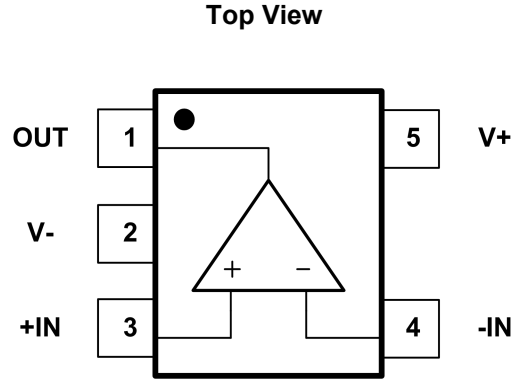
**4 Device Summary, Pin and Packages(Continued)**

**Fig.4-1. GT321: S5(SOT23-5) Package**

**Fig.4-2. GT321B: S5(SOT23-5) Package**
**Table 4-2 Pin Definition**

Name	Pin		I/O	Description
	S5	BS5		
-IN	3	4	I	Negative (inverting) input
+IN	1	3	I	Positive(noninverting) input
NC	-	-	-	No internal connection (can be left floating)
OUT	4	1	O	Output
V-	2	2	-	Negative (lowest) power supply
V+	5	5	-	Positive (highest) power supply

\* It is suggested to leave the unconnected pins floating.

### 4 Device Summary, Pin and Packages(Continued)

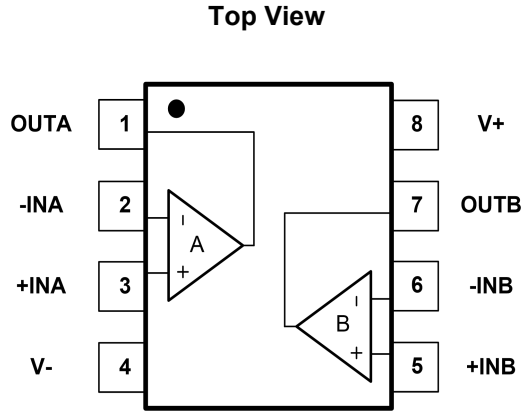

Fig.4-3. GT358: P8(SOP8) Package

GT358: M8(MSOP8) Package

GT358: T8(TSSOP8) Package

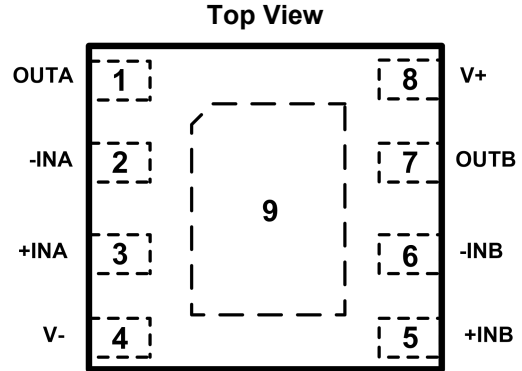

Fig.4-4. GT358: F8(DFN2\*2-8L) Package

Table 4-3 Pin Definition

Name	Pin	I/O	Description
	P8 M8 T8 F8		
-INA	2	I	Inverting input, channel A
+INA	3	I	Noninverting input, channel A
-INB	6	I	Inverting input, channel B
+INB	5	I	Noninverting input, channel B
OUTA	1	O	Output, channel A
OUTB	7	O	Output, channel B
V-	4	-	Negative (lowest) power supply
V+	8	-	Positive (highest) power supply

\* It is suggested to leave the unconnected pins floating

### 4 Device Summary, Pin and Packages(Continued)

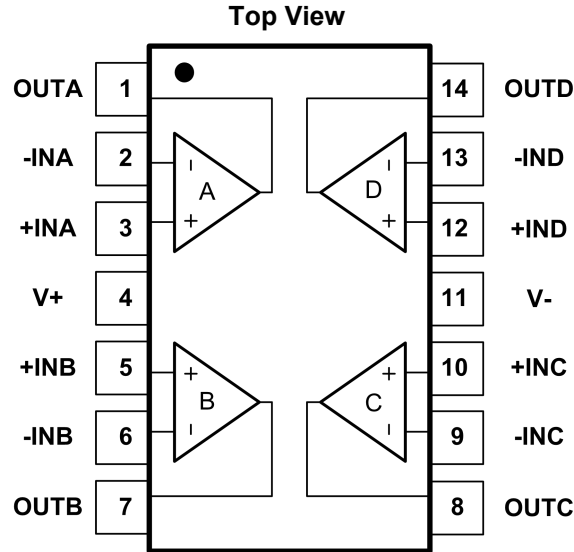

**Fig.4-5. GT324: TD(TSSOP14) Package**  
**GT324: PD(SOP14) Package**

**Table 4-4 Pin Definition**

Name	Pin	I/O	Description
	PD TD		
-INA	2	I	Inverting input, channel A
+INA	3	I	Noninverting input, channel A
-INB	6	I	Inverting input, channel B
+INB	5	I	Noninverting input, channel B
-INC	9	I	Inverting input, channel C
+INC	10	I	Noninverting input, channel C
-IND	13	I	Inverting input, channel D
+IND	12	I	Noninverting input, channel D
OUTA	1	O	Output, channel A
OUTB	7	O	Output, channel B
OUTC	8	O	Output, channel C
OUTD	14	O	Output, channel D
V-	11	-	Negative (lowest) power supply
V+	4	-	Positive (highest) power supply

\* It is suggested to leave the unconnected pins floating.

## 5 Voltage, Temperature, ESD and Thermal Ratings

### 5.1 Absolute Maximum Ratings

Parameters <sup>(1)</sup>	Min.	Max.	Unit
Supply Voltage, $V_S=(V+) - (V-)$	0	40	V
Select Input Voltage <sup>(2)</sup>	(V-)-0.3	(V+)+0.3	V
Maximum Junction Temperature	-45	160	°C
Storage Temperature Range	-65	150	°C

(1) Stresses above these ratings may cause permanent damage. Exposure to absolute maximum conditions for extended periods may degrade device reliability. These are stress ratings only, and functional operation of the device at these or any other conditions beyond those specified is not implied.

(2) Input terminals are diode-clamped to the power-supply rails. Input signals that can swing more than 0.3V beyond the supply rails should be current-limited to 10mA or less.

### 5.2 ESD Ratings

ESD		Value	Unit	
V(ESD)	Electrostatic Discharge	Human-Body Model (HBM) <sup>(1)</sup>	3 K	V
		Charged-Device Model (CDM) <sup>(2)</sup>	3 K	V

(1) JEDEC document JEP155 states that 500-V HBM allows safe manufacturing with a standard ESD control process.

(2) JEDEC document JEP157 states that 250-V CDM allows safe manufacturing with a standard ESD control process.

### 5.3 Recommended Operating Conditions

Over operating free-air temperature range (unless otherwise noted)

Symbol	Parameters	Min	Max	Unit
$V_{CC}$	Single-Supply, $V_S=(V+) - (V-)$	3	36	V
	Dual-Supply, $V_S=(V+) - (V-)$	±1.5	±18	V
TA	Operating Temperature	-40	125	°C

## 6 Electrical Specifications

$V_S=30V$ , and  $R_L=10k\Omega$  connected to  $V_S/2$ , and  $V_{OUT}=V_S/2$ . Typical values are at  $T_A=+25^\circ C$ . (unless otherwise noted)

Parameter	Symbol	Test Conditions	Min	Typ	Max	Units
Offset						
Input Offset Voltage	$V_{OS}$	$(V_S+)=15V, (V_S-)= -15V$	-3	$\pm 0.35$	3	mV
$V_{OS}$ VS Temperature	$dV_{OS}/dT$	$V_S=30V, T_A=-40^\circ C$ to $125^\circ C$		$\pm 2$		$\mu V/^\circ C$
Power-Supply Rejection Ratio	PSRR	$V_S=30V, T_A=-40^\circ C$ to $125^\circ C$	70	100		dB
Power supply						
Power Supply	$V_S$	No load	3		36	V
Quiescent Current/Per	$I_Q$	No load		100	180	$\mu A$
Input						
Common Mode Voltage Range	$V_{cm}$		(V-)		(V+)-1.5	V
Common Mode Rejection Ratio	CMRR	$(V-) < V_{cm} < (V+) - 1.5$	65	120		dB
Differential	Input cap			7.7		pF
Common Mode	Input cap			9		pF
Input Bias Current	$I_B$	$T_A=-40^\circ C$ to $85^\circ C$		30		$\mu A$
Input Offset Current	$I_{OS}$			2		$\mu A$
Output						
Voltage Output Swing	$V_O$	$V_S=30V, I_{out}=-1mA$		0.5	1.5	V
Short Circuit Current	$I_{SC}$	$V_S=30V$		35		mA
AC						
Open Loop Voltage Gain	$A_{OL}$		85	100		dB
Slew Rate	SR	$V_S=-15V, V_S+=15V, AV=1, V_{out}=-1V$ to $1V, C_{load}=30pF, R_{load}=10k\Omega$		0.78		V/ $\mu S$
Gain-Bandwidth Product	GBW	$V_S=5V$		1.5		MHz
Gain Margin	GM			12		dB
Phase Margin	PM			60		$^\circ$
Setting time, 0.1%	$t_s$	$V_S=-15V, V_S+=15V, AV=1, 2-V$ step, $C_{load}=60pF, R_{load}=10k\Omega$				
Noise						
Total Harmonic Distortion+Noise	THD+N	$V_S=30V, AV=1, f=1KHz, R_{load}=10k\Omega, V_{out}=1V_{pp}$		0.002		%
Input Voltage Noise	$E_N$	$V_S=30V, f=0.1Hz$ to $10Hz$		2.9		$\mu V_{rms}$
Input Voltage Noise Density	$e_N$	$V_S=5V, f=1KHz$		35		nV/ $\sqrt{Hz}$
Input Current Noise Density	$I_n$	$V_S=5V, f=1KHz$		23		fA/ $\sqrt{Hz}$

## 7 Typical Characteristics

At  $T_A=+25^{\circ}\text{C}$ ,  $V_{CC}=30\text{V}$ ,  $R_L=10\text{K}\Omega$  connected to  $V_{CC}/2$ ,  $V_{OUT}=V_{CC}/2$ . (unless otherwise noted)

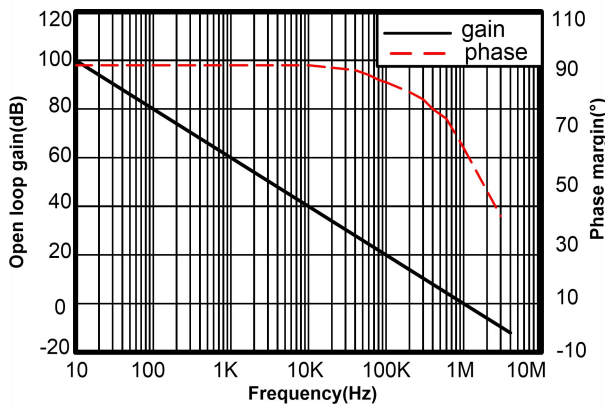

**Fig.7-1. Loop Gain and Phase vs Frequency**

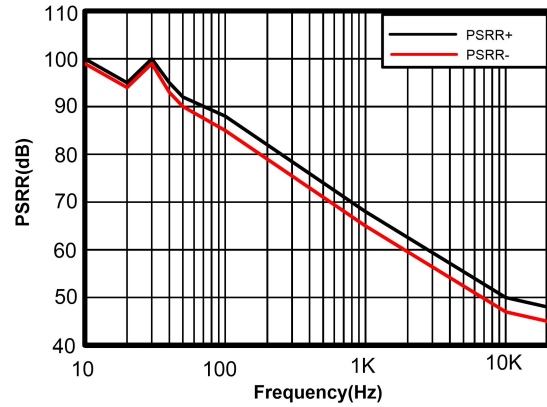

**Fig.7-2. PSRR vs Frequency**

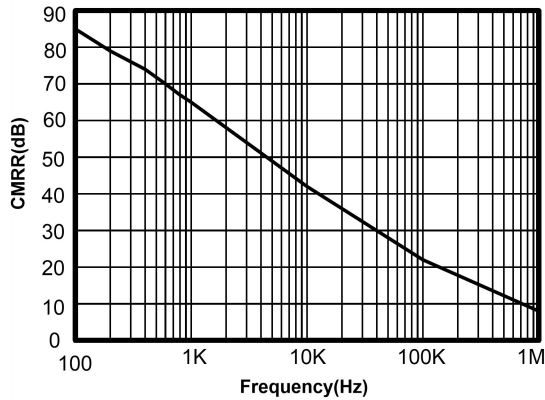

**Fig.7-3. CMRR vs Frequency**

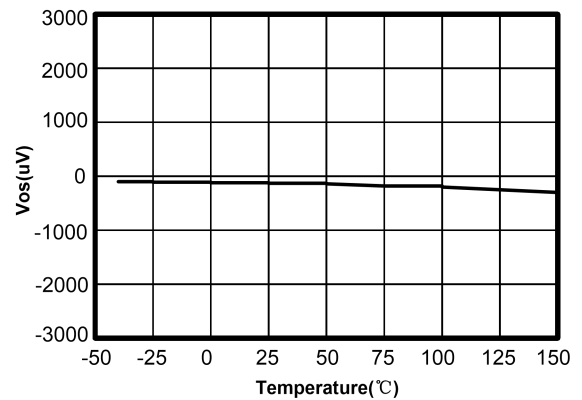

**Fig.7-4. Offset Voltage vs Temperature**

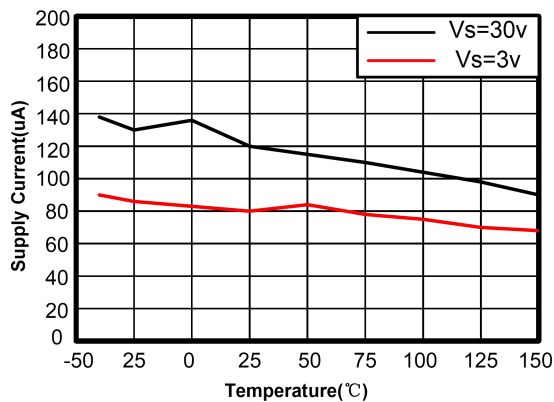

**Fig.7-5. Quiescent Current vs Temperature**

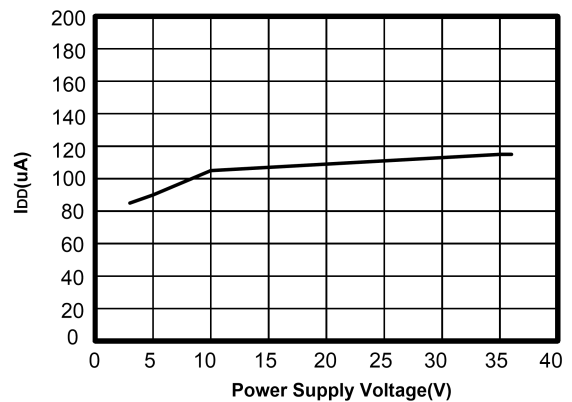

**Fig.7-6.  $I_Q$  vs Power Supply Voltage(25°C)**

## 8 Detailed Description

These devices contain four independent high gain frequency compensation op amps designed for single supply over a wide voltage range. Dual-supply operation is also possible if the voltage difference between the two supplies is between 3V and 36V and  $V_{CC}$  is at least 1.5V higher than the positive value of the input common-mode voltage. The low supply current drain is independent of the magnitude of the supply voltage. Applications include sensor amplifiers, DC amplifiers, and all traditional op amp circuits, which can now be more easily implemented in single-supply voltage systems.

The valid common-mode range is from device ground to  $V_{CC}-1.5V$  ( $V_{CC}-2V$  over temperature). The input may exceed  $V_{CC}$  up to the maximum  $V_{CC}$  without damaging the device. At least one input must be within a valid input common-mode range for the output to have the correct phase. If both inputs are outside the valid range, the output phase is undefined. If either input is below  $-0.3V$ , the input current should be limited to 1mA and the output phase should be undefined.

Slew rate is the rate at which the op amp can change the output when the input changes. Slew rates are better for different occasions, sometimes bigger is better, sometimes smaller is better, GT321,GT358, GT324, these devices have a slew rate of 1.0 V/ $\mu$ S.

The gain-bandwidth product is equal to the measured amplifier bandwidth multiplied by the gain corresponding to the measured bandwidth. For op amps, the increase in bandwidth means an increase in speed, but at the same time it brings a large amount of power consumption, for general occasions, the bandwidth around 1MHz can take into account the balance of all aspects of the op amp parameters, these devices have a high gain bandwidth of 1.0MHz.

GT321, GT358,GT324 features a low input offset voltage as low as 0.35mV typical from a high voltage supply because the input offset voltage is amplified by noise gain, creating offset errors at the output. For a high-voltage general-purpose op amp, the application scenarios and scope of the op amp are maximized while minimizing the design of the low offset voltage while taking into account other op amp parameters. It is especially suitable for some occasions with high sensitivity.

## 9 Application Note

Op amps are suitable for a variety of signal conditioning applications. The input can be powered before  $V_s$ , allowing flexibility in multiple supply circuits. The amplifier accepts a positive voltage at the input and then changes the voltage to a negative voltage of the same magnitude. It also turns the negative input voltage into positive in the same way.

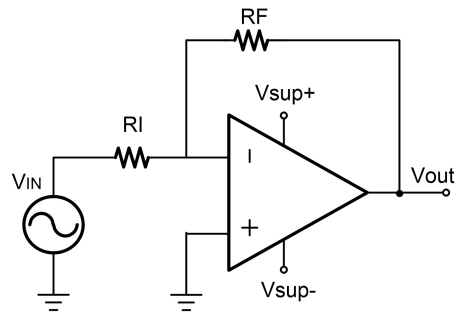

**Fig.9-1. Dual-Supply Amplifier**

# 10 Package Outline Dimension

SOT23-5

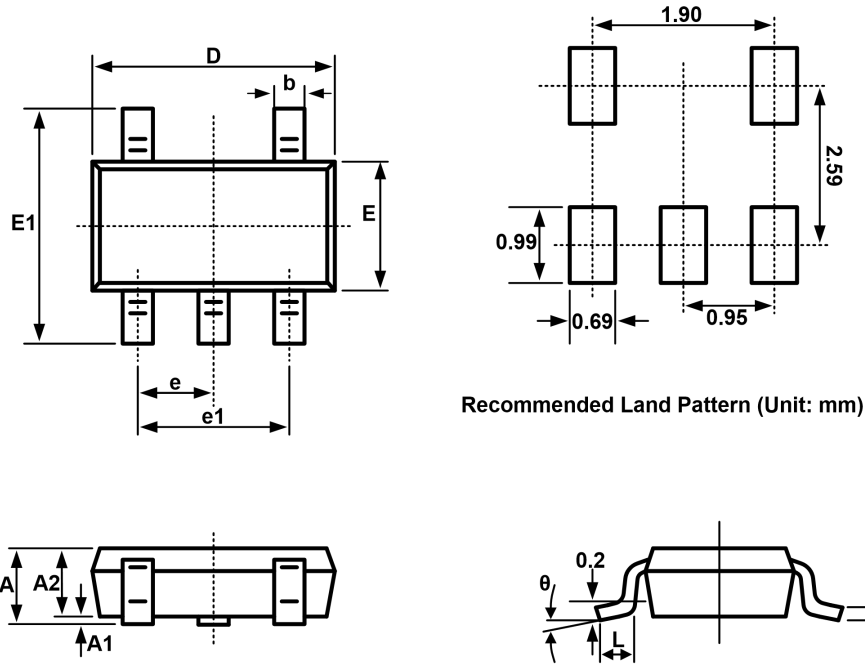

Recommended Land Pattern (Unit: mm)

Symbol	Dimensions in Millimeters		Dimensions in Inches	
	Min.	Max.	Min.	Max.
A	1.050	1.250	0.041	0.049
A1	0.000	0.100	0.000	0.004
A2	1.050	1.150	0.041	0.045
b	0.300	0.500	0.012	0.020
c	0.100	0.200	0.004	0.008
D	2.820	3.020	0.111	0.119
E	1.500	1.700	0.059	0.067
E1	2.650	2.950	0.104	0.116
e	0.950(BSC)		0.037(BSC)	
e1	1.800	2.000	0.071	0.079
L	0.300	0.600	0.012	0.024
θ	0°	8°	0°	8°
<b>Symbol</b>	<b>Dimensions in Millimeters</b>		<b>Dimensions in Inches</b>	

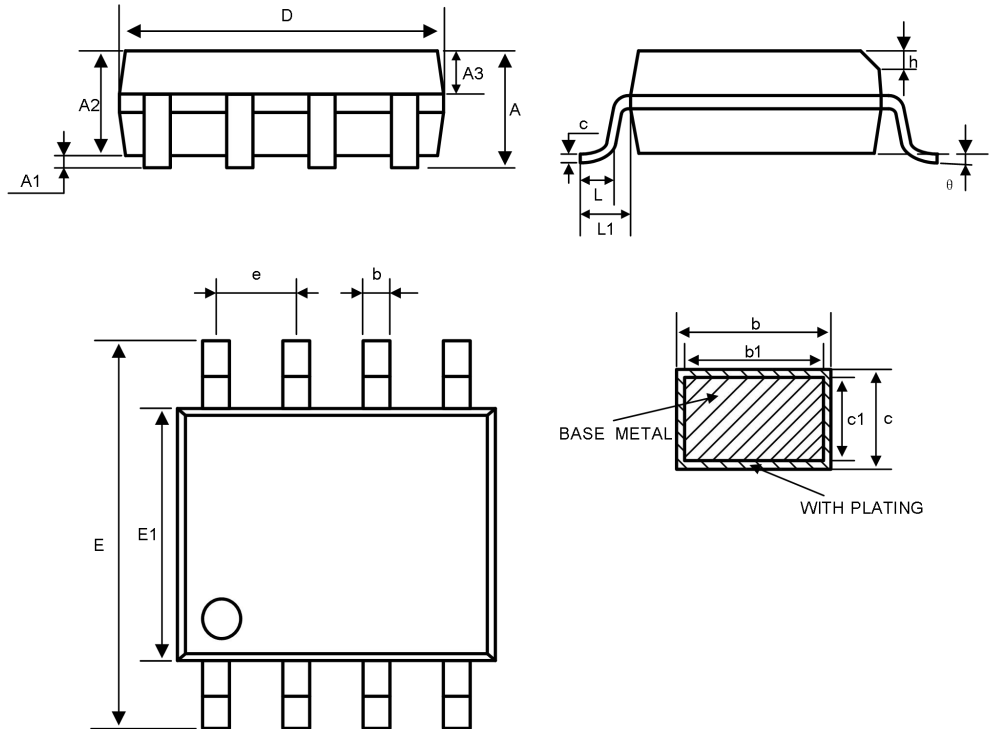
**10 Package Outline Dimension(Continued)**
**SOP8**

Symbol	Dimensions in Millimeters			Dimensions in Inches		
	Min.	Nom.	Max.	Min.	Nom.	Max.
A	—	—	1.75	—	—	0.069
A1	0.10	—	0.225	0.004	—	0.009
A2	1.30	1.40	1.50	0.051	0.055	0.059
A3	0.60	0.65	0.70	0.024	0.026	0.028
b	0.39	—	0.47	0.015	—	0.019
b1	0.38	0.41	0.44	0.015	0.016	0.017
c	0.20	—	0.24	0.008	—	0.009
c1	0.19	0.20	0.21	0.007	0.008	0.008
D	4.80	4.90	5.00	0.189	0.193	0.197
E	5.80	6.00	6.20	0.228	0.236	0.244
E1	3.80	3.90	4.00	0.150	0.154	0.157
e	1.27BSC			0.05BSC		
h	0.25	—	0.50	0.010	—	0.020
L	0.50	—	0.80	0.020	—	0.031
L1	1.05REF			0.041REF		
theta	0	—	8°	0	—	8°

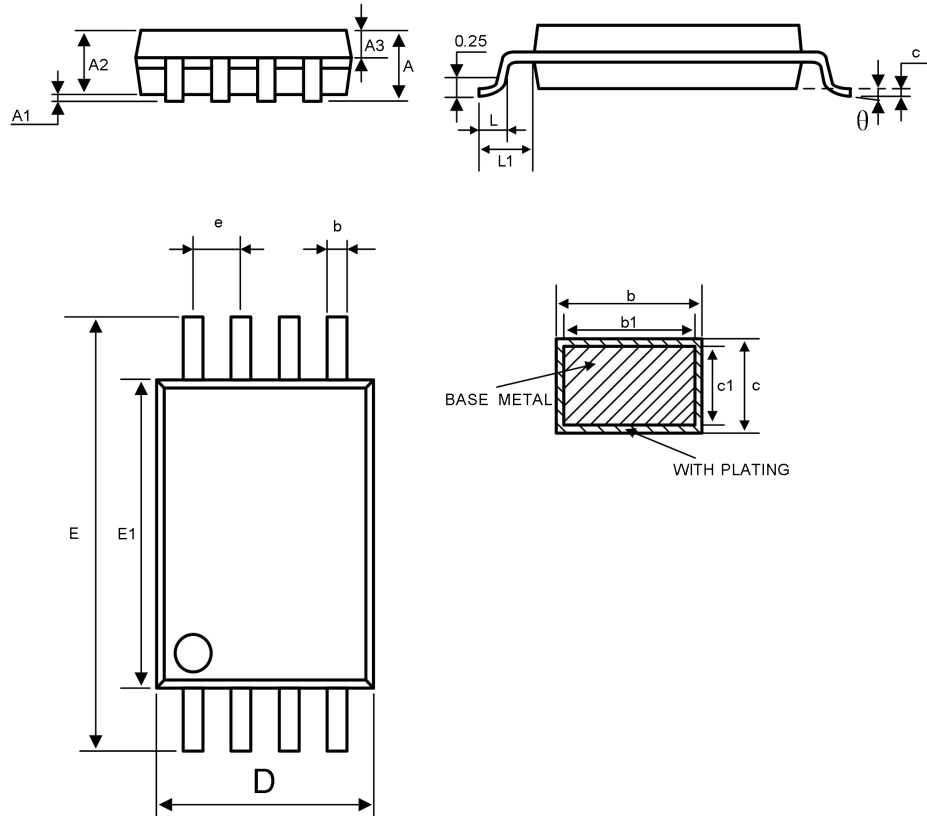
**10 Package Outline Dimension(Continued)**
**TSSOP8**

Symbol	Dimensions in Millimeters			Dimensions in Inches		
	Min.	Nom.	Max.	Min.	Nom.	Max.
A	—	—	1.20	—	—	0.047
A1	0.05	—	0.15	0.002	—	0.006
A2	0.90	1.00	1.05	0.035	0.039	0.041
A3	0.39	0.44	0.49	0.015	0.017	0.019
b	0.20	—	0.28	0.008	—	0.011
b1	0.19	0.22	0.25	0.007	0.009	0.010
c	0.13	—	0.17	0.005	—	0.007
c1	0.12	0.13	0.14	0.005	0.005	0.006
D	2.90	3.00	3.10	0.114	0.118	0.122
E1	4.30	4.40	4.50	0.169	0.173	0.177
E	6.20	6.40	6.60	0.244	0.251	0.260
e	0.65BSC			0.026BSC		
L	0.45	—	0.75	0.018	—	0.030
L1	1.00REF			0.039REF		
θ	0	—	8°	0	—	8°

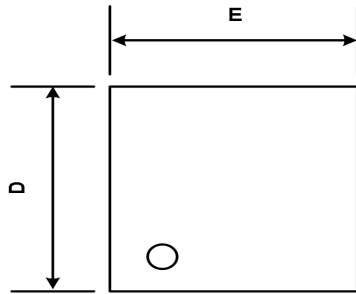
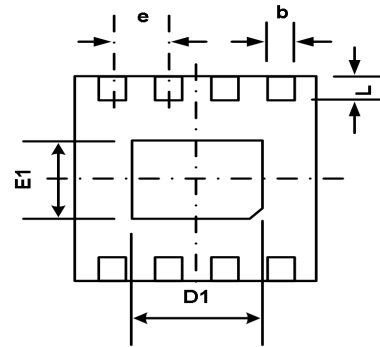
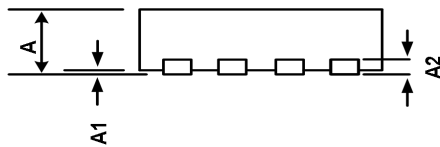
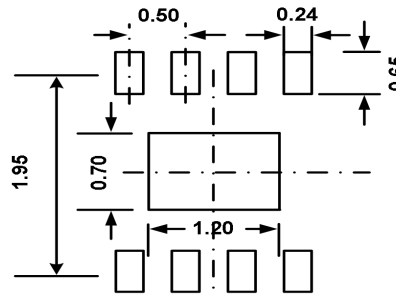
**10 Package Outline Dimension(Continued)**
**DFN2×2-8L**

**TOP VIEW**

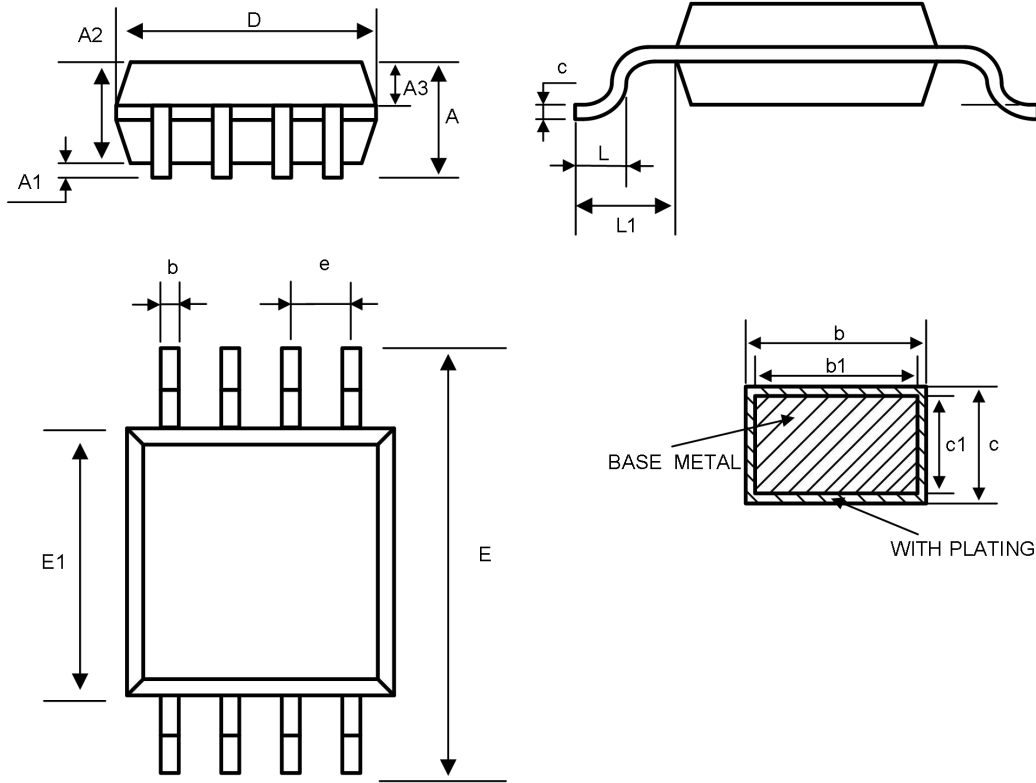
**BOTTOM VIEW**

**SIDE VIEW**

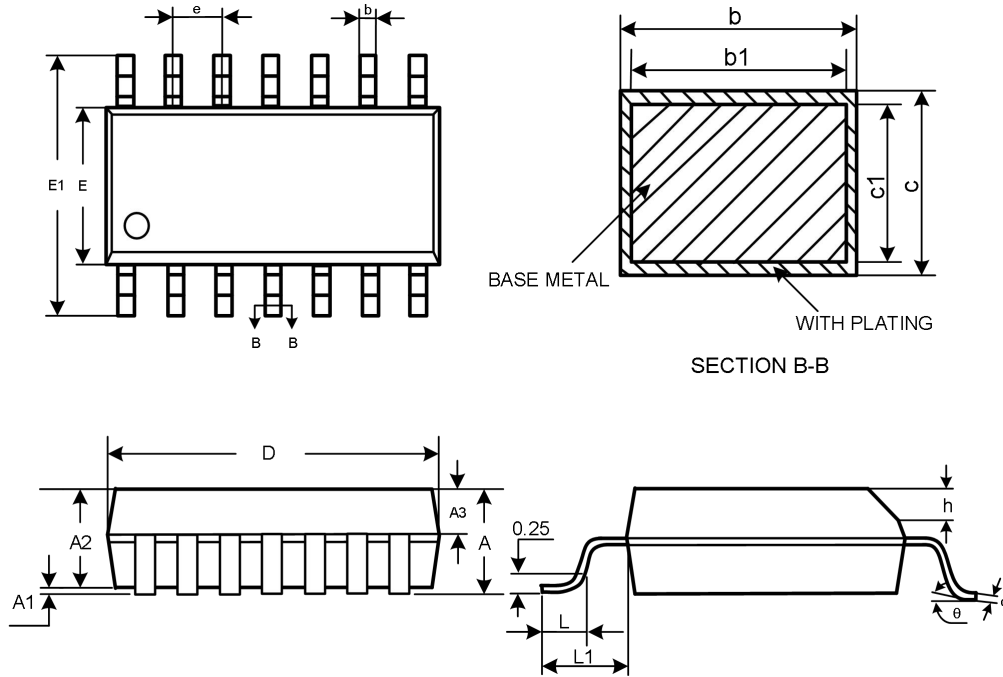
**RECOMMENDED LAND PATTERN(unit:mm)**

Symbol	Dimensions in Millimeters		Dimensions in Inches	
	Min.	Max.	Min.	Max.
A	0.700	0.800	0.028	0.031
A1	0.000	0.050	0.000	0.002
A2	0.203(TYP)		0.035(TYP)	
b	0.180	0.300	0.007	0.012
D	1.900	2.100	0.075	0.083
D1	1.100	1.300	0.043	0.051
E	1.900	2.100	0.075	0.083
E1	0.600	0.800	0.024	0.031
e	0.500(TYP)		0.020TYP	
L	0.250	0.450	0.010	0.018

**10 Package Outline Dimension(Continued)**
**MSOP8**

Symbol	Dimensions in Millimeters			Dimensions in Inches		
	Min.	Nom.	Max.	Min.	Nom.	Max.
A	—	—	1.10	—	—	0.043
A1	0.05	—	0.15	0.002	—	0.006
A2	0.75	0.85	0.95	0.030	0.033	0.037
A3	0.30	0.35	0.40	0.012	0.014	0.016
b	0.28	—	0.36	0.011	—	0.014
b1	0.27	0.30	0.33	0.011	0.012	0.013
c	0.15	—	0.19	0.006	—	0.007
c1	0.14	0.15	0.16	0.006	0.006	0.006
D	2.90	3.00	3.10	0.114	0.118	0.122
E	4.70	4.90	5.10	0.185	0.193	0.201
E1	2.90	3.00	3.10	0.114	0.118	0.122
e	0.65BSC			0.026BSC		
L	0.40	—	0.70	0.016	—	0.028
L1	0.95REF			0.037REF		
$\theta$	0	—	8°	0	—	8°

**10 Package Outline Dimension(Continued)**
**SOP14**

Symbol	Dimensions in Millimeters			Dimensions in Inches		
	Min	Nom	Max	Min	Nom	Max
A	—	—	1.75	—	—	0.069
A1	0.10	—	0.225	0.004	—	0.009
A2	1.30	1.40	1.50	0.051	0.055	0.059
A3	0.60	0.65	0.70	0.024	0.026	0.028
b	0.39	—	0.47	0.015	—	0.019
b1	0.38	0.41	0.44	0.015	0.016	0.017
c	0.20	—	0.24	0.008	—	0.009
c1	0.19	0.20	0.21	0.007	0.008	0.008
D	8.55	8.65	8.75	0.337	0.341	0.344
E1	5.80	6.00	6.20	0.228	0.236	0.244
E	3.80	3.90	4.00	0.150	0.154	0.157
e	1.27BSC			0.05BSC		
h	0.25	—	0.50	0.010	—	0.020
L	0.50	—	0.80	0.020	—	0.031
L1	1.05REF			0.041REF		
θ	0	—	8°	0	—	8°

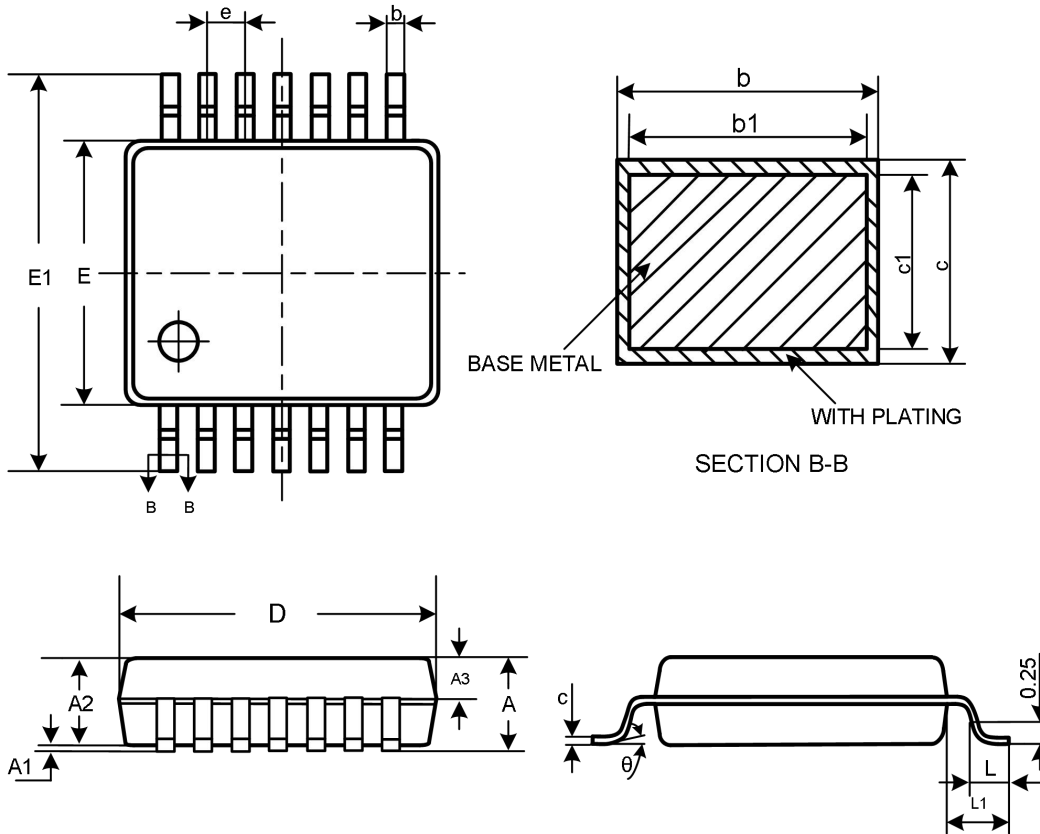
**10 Package Outline Dimension(Continued)**
**TSSOP14**

Symbol	Dimensions in Millimeters			Dimensions in Inches		
	Min	Nom	Max	Min	Nom	Max
A	—	—	1.20	—	—	0.047
A1	0.05	—	0.15	0.002	—	0.006
A2	0.90	1.00	1.05	0.035	0.039	0.041
A3	0.39	0.44	0.49	0.015	0.017	0.019
b	0.20	—	0.28	0.008	—	0.011
b1	0.19	0.22	0.25	0.007	0.009	0.010
c	0.13	—	0.17	0.005	—	0.007
c1	0.12	0.13	0.14	0.005	0.005	0.006
D	4.90	5.00	5.10	0.193	0.197	0.201
E	4.30	4.40	4.50	0.169	0.173	0.177
E1	6.20	6.40	6.60	0.244	0.252	0.260
e	0.65BSC			0.026BSC		
L	0.45	0.60	0.75	0.018	0.024	0.030
L1	1.00BCS			0.039BSC		
θ	0	—	8°	0	—	8°

## 11 Tape and Reel Information

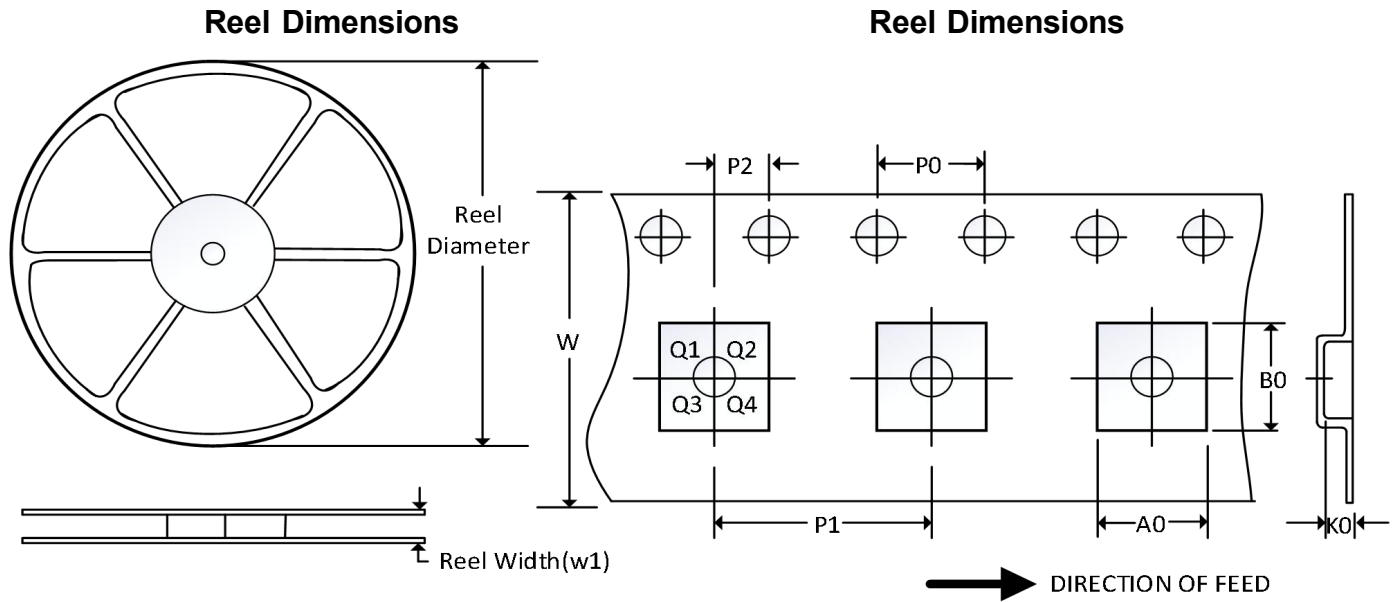

NOTE: The picture is only for reference. Please make the object as the standard.

### Key Parameter List of Tape and Reel

Package Type	Reel Diameter	Reel Width (mm)	A0 (mm)	B0 (mm)	K0 (mm)	P0 (mm)	P1 (mm)	P2 (mm)	W (mm)	Pin1 Quadrant
SOT23-5	7"	9.5	3.20	3.20	1.40	4.0	4.0	2.0	8.0	Q3
MSOP8	13"	12.4	5.20	3.30	1.50	4.0	8.0	2.0	12.0	Q1
TSSOP14	13"	12.4	6.95	5.60	1.20	4.0	8.0	2.0	12.0	Q1
SOP8	13"	12.4	6.40	5.40	2.10	4.0	8.0	2.0	12.0	Q1
TSSOP8	13"	12.4	6.90	3.45	1.65	4.0	8.0	2.0	12.0	Q1
DFN2x2-8L	7"	9.5	2.30	2.30	1.0	4.0	4.0	2.0	8.0	Q2
SOP14	13"	16.4	6.60	9.30	2.10	4.0	8.0	2.0	16.0	Q1

NOTE:

1. All dimensions are nominal.
2. Plastic or metal protrusions of 0.15mm maximum per side are not included.