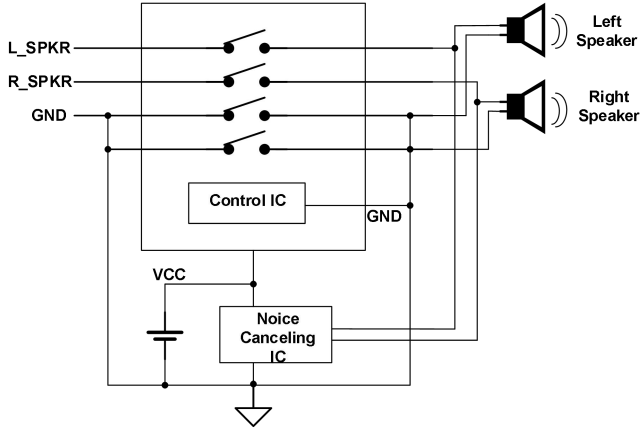

GT550 4PST Depletion Mode Isolation Switch

1 Features	2 Application
<ul style="list-style-type: none"> - 4PST (NC) - Depletion Mode MOSFETS - $V_{CC(OFF)}$: +1.6V to +3.0V - I_{SWPEAK}: 500mA - R_{ON}: 0.6Ω (TYP) - $R_{ON Flat}$: 0.01 Ω Typical - THD+N: 0.002% Typical - Industrial Temperature Range: -40°C to +85°C 	<ul style="list-style-type: none"> - MP3 Portable Media Players - Cellular Phones, Smart Phones

3 Description	Circuit Diagram
<p>The GT550 is a high-performance four-pole single throw (4PST) normally closed Depletion-Mode isolation switch. The Depletion Mode technology allows the device to conduct signals when there is no V_{CC} available and to isolate the signals when V_{CC} is present.</p> <p>The GT550 operates on a wide V_{CC} range for design flexibility. Additionally, select pins allow the internal oscillator frequency to be adjusted between 500 kHz and 750 kHz in 75 kHz steps when V_{CC} is present. This feature is used to shift the electromagnetic interference (EMI) signature to meet customer specifications.</p>	 <p>The circuit diagram shows the internal structure of the GT550. It features a central 'Control IC' and a 'Noise Canceling IC'. The Control IC is connected to a VCC supply and GND. It controls four switches that connect the L_SPKR and R_SPKR inputs to the Left Speaker and Right Speaker outputs. The Noise Canceling IC is also connected to VCC and GND, and its output is connected to the speaker outputs. The VCC supply is represented by a battery symbol.</p>

4 Device Summary, Pin and Packages

Table 5-1. Device Summary ⁽¹⁾

Serial Name	Part Name	Package	Body Size (Nom)	Marking ⁽²⁾	MSL ⁽³⁾	Package Qty
GT550	GT550WLG	WLCSP-12L	1.17mm×1.57mm×0.582mm	GT550 XXXXX	3	Tape and Reel,3000
	GT550QSE	QFN3×3-16L	3.00mm×3.00mm×0.75mm	GT550 XXXXX	3	Tape and Reel,5000

(1) For all available packages, please contact product sales.

(2) There may be additional marking, which relates to the lot trace code information (data code and vendor code), the logo or the environmental category on the device.

(3) MSL, The Moisture Sensitivity Level rating according to the JEDEC industry standard classifications.

(4) "XXXXX" in Marking will be appeared as the batch code.

4 Device Summary, Pin and Packages (Continued)

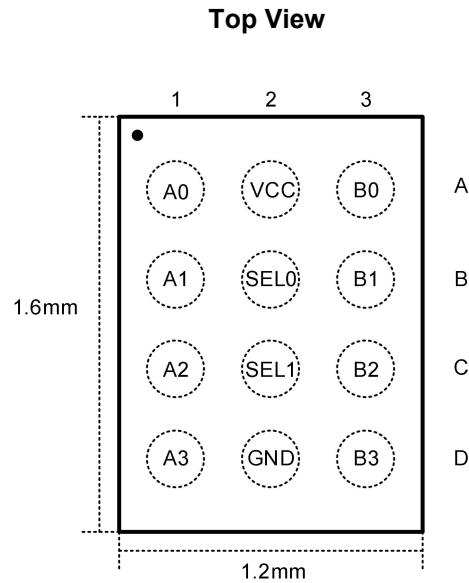

Fig.5-1.GT550: WLG (WLCSP-12L) Package

Table 5-2 Pin Description

No.	Pin#	Name	Type	Description
1	A1	A0	I/O	A-Port
2	B1	A1	I/O	A-Port
3	C1	A2	I/O	A-Port
4	D1	A3	I/O	A-Port
5	A2	V _{CC}	P	Supply Voltage
6	B2	SEL0	I	Oscillator Frequency Control (see Table 5-4). Used to shift the electromagnetic interference (EMI) signature to meet the customer specifications
7	C2	SEL1	I	
8	D2	GND	G	Ground
9	A3	B0	I/O	B-Port
10	B3	B1	I/O	B-Port
11	C3	B2	I/O	B-Port
12	D3	B3	I/O	B-Port

4 Device Summary, Pin and Packages (Continued)

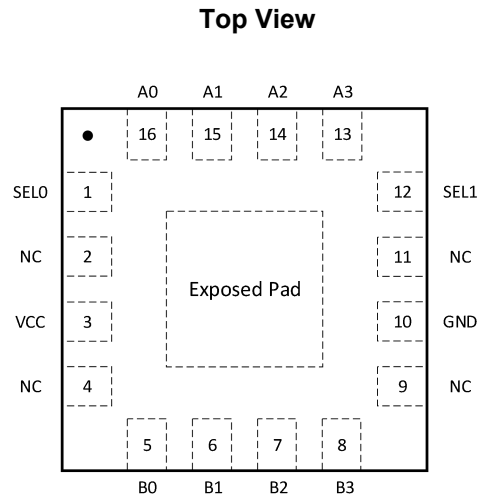

Fig.5-3.GT550: QSE (QFN3x3-16L) Package

Table 5-4 Pin Description

No.	Name	Type	Description
1	SEL0	I	Oscillator Frequency Control (see Table 5-4). Used to shift the electromagnetic interference (EMI) signature to meet the customer specifications
12	SEL1	I	
2	NC	-	No Connect
3	V _{CC}	P	Supply Voltage
4	NC	-	No Connect
5	B0	I/O	B-Port
6	B1	I/O	B-Port
7	B2	I/O	B-Port
8	B3	I/O	B-Port
9	NC	-	No Connect
10	GND	G	Ground
11	NC	-	No Connect
13	A3	I/O	A-Port
14	A2	I/O	A-Port
15	A1	I/O	A-Port
16	A0	I/O	A-Port
--	Exposed Pad	G	Ground or Float

4 Device Summary, Pin and Packages (Continued)

Table 5-3 Truth Table

V_{CC}	Function
0V~0.2V	Conduction: B0~B3=A0~A3
1.6V~3.0V	Isolation: B0~B3≠A0~A3

Table 5-4 Oscillator Frequency Step Logic

SEL1	SEL0	Frequency (TYP)
Low	Low	500kHz
Low	High	575kHz
High	Low	650kHz
High	High	725kHz

5 Voltage, Temperature, ESD and Thermal Ratings

5.1 Absolute Maximum Ratings ⁽¹⁾

Parameters		Min.	Max.	Unit
V _{CC}	Supply/Control Voltage	0	4.6	V
V _{IN}	Input Voltage (Select Pins) ⁽²⁾	0	V _{CC}	
V _{SW(ON)}	DC Switch I/O Voltage (Switch Conducting)	-5	+5	
V _{SW(OFF)}	DC Switch I/O Voltage (Switch Isolated) ⁽³⁾	-1.8	+3.0	
I _{IK}	DC Input Diode Current	-50		mA
I _{SW}	Switch I/O Current		350	
I _{SWPEAK}	Peak Switch Current		500	
T _A	Absolute Maximum Operating Temperature	-40	+85	°C
T _{STG}	Storage Temperature	-65	+150	°C

(1) Stresses beyond those listed under "Absolute Maximum Ratings" may cause permanent damage to the device. These are stress ratings only, and functional operation of the device at these or any other conditions beyond those indicated under "Recommended Operating Conditions" is not implied. Exposure to absolute-maximum-rated conditions for extended periods may affect device reliability.

(2) The input and output negative-voltage ratings may be exceeded if the input and output current ratings are observed.

(3) When a switch is isolated (OFF), V_{SW} value must be < V_{CC};

5.2 ESD Ratings

ESD		Value	Unit	
V(ESD)	Electrostatic Discharge	Human-Body Model (HBM) ⁽¹⁾	5K	V
		Charged-Device Model (CDM) ⁽²⁾	2K	V

(1) JEDEC document JEP155 states that 500-V HBM allows safe manufacturing with a standard ESD control process.

(2) JEDEC document JEP157 states that 250-V CDM allows safe manufacturing with a standard ESD control process.

5.3 Recommended Operating Conditions

Over operating free-air temperature range (unless otherwise noted)⁽¹⁾

Symbol	Parameter		Min	Max	Unit
V _{CC(ON)}	Supply Voltage with Switch Conducting		0	0.2	V
V _{CC(OFF)}	Supply Voltage with Switch Isolated		1.6	3.0	V
V _{SW(ON)}	DC Switch I/O Voltage (Switch Conducting)	V _{CC} =0 V	-2.0	2.0	V
V _{SW(OFF)}	DC Switch I/O Voltage (Switch Isolated)	V _{CC} =1.6 V to 3.0 V	-1.5	+1.5	V

(1) All unused digital inputs of the device must be held at V_{CC} or GND to ensure proper device operation.

6 Electrical Specifications

6.1 DC Electrical Characteristics

Typical values are at $T_A=+25^\circ\text{C}$. (unless otherwise noted)

Symbol	Parameter	Conditions	V _{CC}	Min	Typ	Max	Units
I _{ON}	Switch-to-GND Leakage Current (Switch Conducting)	An=-1.4 V to 1.4 V Bn=Float	0	0	0.3	1.5	μA
I _{OFF}	Switch-to-GND Leakage Current (Switch Isolated)	An=0.4 V to 1.4 V, Bn=Float	3	0	0.5	2	μA
R _{ON}	Switch On Resistance	I _{SW} =±24 mA V _{SW} =-1.4 V to +1.4 V	0		0.8		Ω
R _{FLAT(ON)}	On Resistance Flatness	I _{SW} =±24 mA, V _{SW} =-1.4 V to +1.4 V	0		0.01		Ω
I _{CC}	Quiescent Supply Current	SEL0=SEL1 = V _{CC}	3	0	45	70	μA
V _{IH}	Input Voltage High (Select Pins)		3	0.8V _{CC}			V
V _{IL}	Input Voltage Low (Select Pins)		3			0.2V _{CC}	V
I _{IN}	Input Leakage Current (Select Pins)		3	0		±1	μA

6.2 Switch and AC Characteristics

Typical values are at $T_A=+25^\circ\text{C}$. (unless otherwise noted)

Symbol	Parameter	Conditions	V _{CC}	Typ	Units
t _{ON}	Turn-On Time	R _L =32 Ω, C _L =10 pF, V _{SW} =1.4 V	1.6	120	ns
t _{OFF}	Turn-Off Time	R _L =32 Ω, C _L =10 pF, V _{SW} =1.4 V	1.6	160	ns
BW	-3 dB Bandwidth	R _L =50 Ω, C _L =0 pF	0	<100	MHz
O _{IRR}	Off-Isolation	R _L =32 Ω, f=20 kHz, V _{SW} =0.35 V _{RMS}	1.6	-90	dB
X _{TALK}	Crosstalk	R _L =32 Ω, f=20 kHz, V _{SW} =1 V _{RMS}	0	-85	dB
THD+N	Total Harmonic Distortion + Noise	R _L =32 Ω, f=20 Hz to 20 kHz, V _{SW} =1 V _{RMS}	0	0.002	%
C _{ON}	On Capacitance	V _{CC} =0 V, f=1 MHz, 400 mVPP	0	10	pF
C _{OFF}	Off Capacitance	V _{CC} =1.6 V, f=1 MHz, 400 mVPP	1.6	10	pF

7 Package Outline Dimension

WLCSP-12

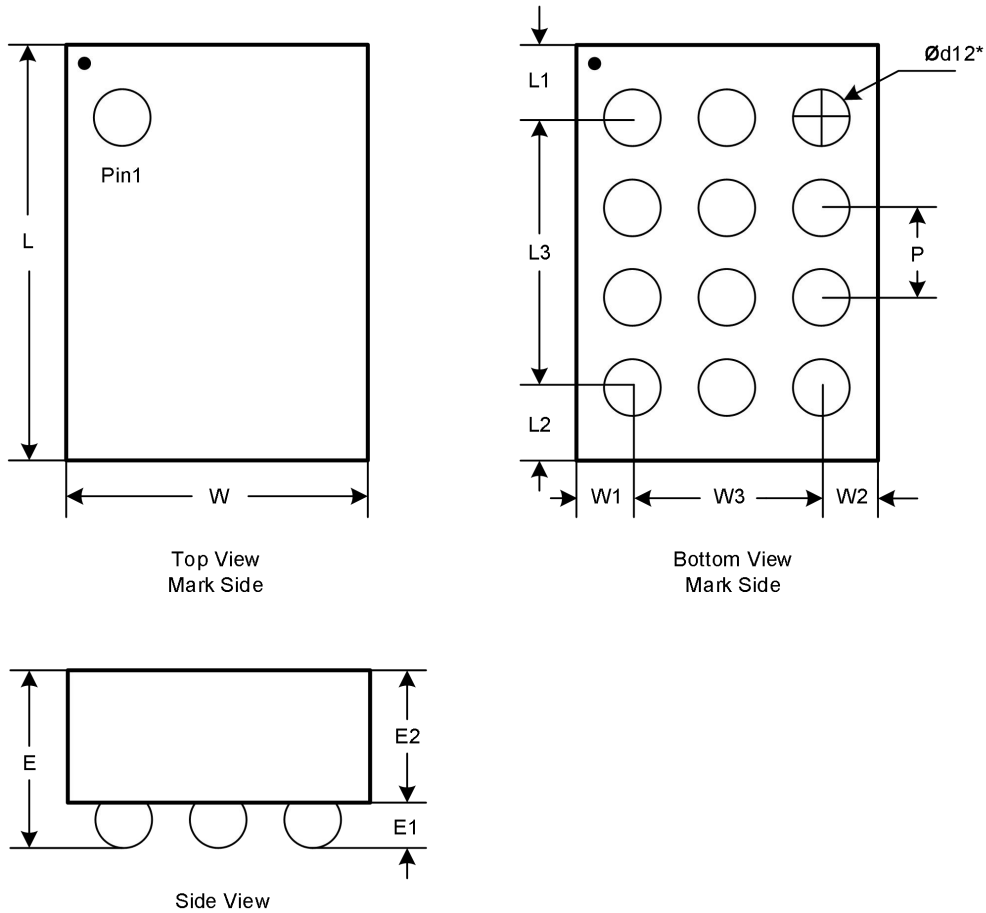

Symbol	Dimensions in Millimeters			Dimensions in Inches		
	Min.	Nom.	Max.	Min.	Nom.	Max.
E	0.542	0.582	0.622	0.021	0.023	0.024
E1	0.177	0.202	0.227	0.007	0.008	0.009
E2	0.355	0.380	0.405	0.014	0.015	0.016
L	1.540	1.570	1.600	0.061	0.062	0.063
L3	1.200BSC			0.047BSC		
W	1.140	1.170	1.200	0.045	0.046	0.047
W3	0.800			0.031		
d	0.243	0.268	0.293	0.010	0.011	0.012
p	0.40			0.016BSC		
W1	0.185REF			0.007REF		
W2	0.185REF			0.007REF		
L	0.185REF			0.007REF		
L2	0.185REF			0.007REF		

7 Package Outline Dimension (Continued)

QFN3×3-16L

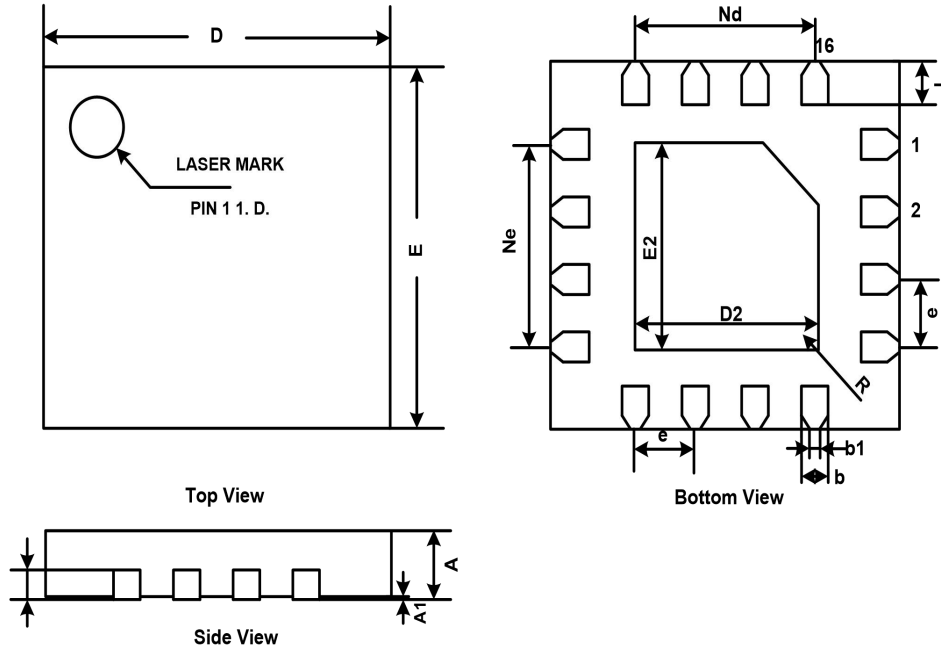

Symbol	Dimensions in Millimeters		Dimensions in Inches	
	Min	Max	Min	Min
A	0.700	0.800	0.028	0.032
A1	0.000	0.050	0.000	0.002
b	0.200	0.300	0.008	0.012
b1	0.230REF		0.009REF	
c	0.203REF		0.008REF	
D	2.900	3.100	0.116	0.124
D2	1.600	1.700	0.064	0.068
e	0.500BSC		0.020BSC	
Nd	1.500BSC		0.060BSC	
Ne	1.500BSC		0.060BSC	
E	2.900	3.100	0.116	0.124
E2	1.600	1.700	0.064	0.068
L	0.350	0.450	0.014	0.018
h	0.250	0.350	0.010	0.014
K	0.225	0.325	0.009	0.013
R	0.075REF		0.003REF	

8 Type and Reel Information

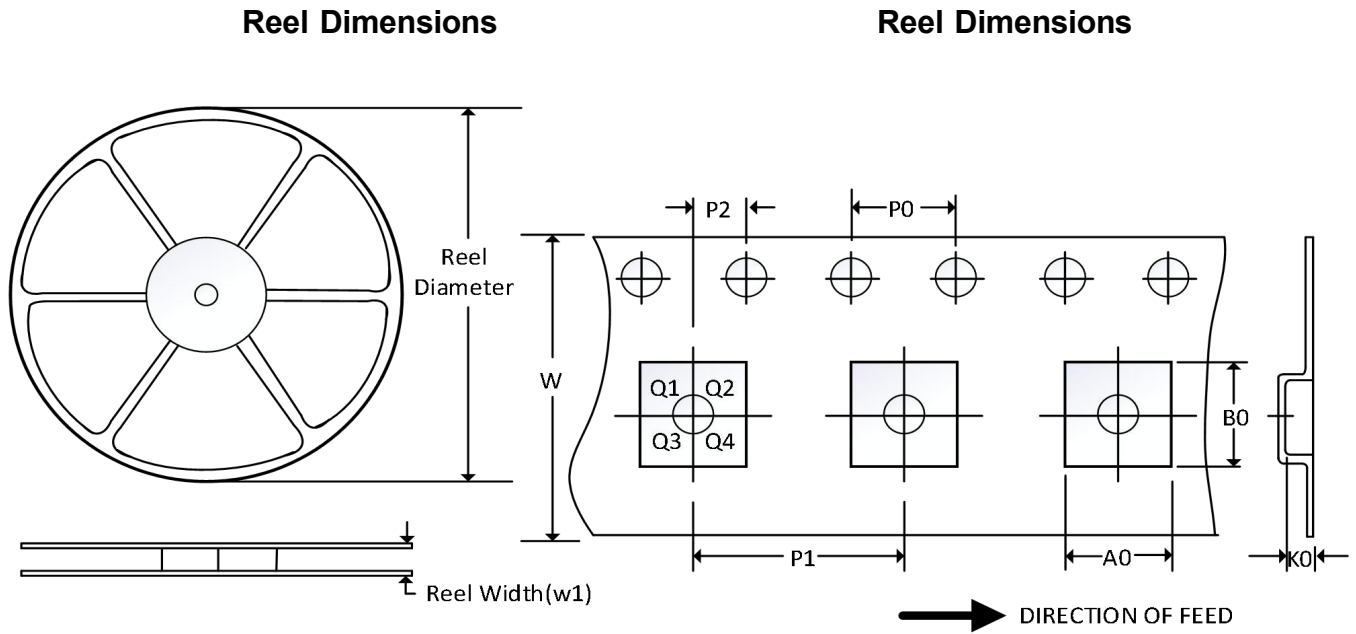

NOTE: The picture is only for reference. Please make the object as the standard.

Key Parameter List of Tape and Reel

Package Type	Reel Diameter	Reel Width (mm)	A0 (mm)	B0 (mm)	K0 (mm)	P0 (mm)	P1 (mm)	P2 (mm)	W (mm)	Pin1 Quadrant
QFN3X3-16L	13"	12.4	3.35	3.35	1.30	4.0	8.0	2.0	12.0	Q1
WLCSP1.6X1.2-12L	7"	8.3	1.35	1.75	0.70	4.0	4.0	2.0	8.0	Q1

NOTE:

1. All dimensions are nominal.
2. Plastic or metal protrusions of 0.15mm maximum per side are not included.